

*Test Code: CS (Short answer type) 2009*

*M.Tech. in Computer Science*

The candidates for M.Tech. in Computer Science will have to take two tests – Test MIII (objective type) in the forenoon session and Test CS (short answer type) in the afternoon session. The CS test booklet will have two groups as follows.

GROUP A

A test for all candidates in analytical ability and mathematics at the B.Sc. (pass) level, carrying 30 marks.

GROUP B

A test, divided into several sections, carrying equal marks of 70 in mathematics, statistics, and physics at the B. Sc. (Hons.) level, and in computer science, and engineering and technology at the B.Tech. level. A candidate has to answer questions from **only one** of these sections according to his/her choice.

The syllabi and sample questions for the CS test are given below.

**Note: Not all questions in the sample set are of equal difficulty. They may not carry equal marks in the test.**

*Syllabus*

GROUP A

Elements of set theory. Permutations and combinations. Functions and relations. Theory of equations. Inequalities.

Limits, continuity, sequences and series, differentiation and integration with applications, maxima-minima, complex numbers and De Moivre's theorem.

Elementary Euclidean geometry and trigonometry.

Elementary number theory, divisibility, congruences, primality.

Determinants, matrices, solutions of linear equations, vector spaces, linear independence, dimension, rank and inverse.

## GROUP B

### *Mathematics* (B.Sc. Hons. level)

In addition to the syllabus for Mathematics in Group A, the syllabus includes:

Calculus and real analysis – real numbers, basic properties; convergence of sequences and series; limits, continuity, uniform continuity of functions; differentiability of functions of one or more variables and applications. Indefinite integral, fundamental theorem of Calculus, Riemann integration, improper integrals, double and multiple integrals and applications. Sequences and series of functions, uniform convergence.

Linear algebra – vector spaces and linear transformations; matrices and systems of linear equations, characteristic roots and characteristic vectors, Cayley-Hamilton theorem, canonical forms, quadratic forms.

Graph Theory – connectedness, trees, vertex coloring, planar graphs, Eulerian graphs, Hamiltonian graphs, digraphs and tournaments.

Abstract algebra – groups, subgroups, cosets, Lagrange's theorem; normal subgroups and quotient groups; permutation groups; rings, subrings, ideals, integral domains, fields, characteristics of a field, polynomial rings, unique factorization domains, field extensions, finite fields.

Differential equations – solutions of ordinary and partial differential equations and applications.

### *Statistics* (B.Sc. Hons. level)

Notions of sample space and probability, combinatorial probability, conditional probability, Bayes' theorem and independence, random variable and expectation, moments, standard univariate discrete and continuous distributions, sampling distribution of statistics based on normal samples, central limit theorem, approximation of binomial to normal. Poisson law, multinomial, bivariate normal and multivariate normal distributions.

Descriptive statistical measures, product-moment correlation, partial and multiple correlation; regression (simple and multiple); elementary theory and methods of estimation (unbiasedness, minimum variance, sufficiency, maximum likelihood method, method of moments, least squares methods). Tests of hypotheses (basic concepts and simple applications of Neyman-Pearson Lemma). Confidence intervals. Tests of regression. Elements of non-parametric inference. Contingency tables and Chi-square, ANOVA, basic designs (CRD/RBD/LSD) and their analyses. Elements of factorial designs. Conventional sampling techniques, ratio and regression methods of estimation.

*Physics*  
(B.Sc. Hons. level)

General properties of matter – elasticity, surface tension, viscosity.  
Classical dynamics – Lagrangian and Hamiltonian formulation, symmetries and conservation laws, motion in central field of force, planetary motion, collision and scattering, mechanics of system of particles, small oscillation and normal modes, wave motion, special theory of relativity.

Electrodynamics – electrostatics, magnetostatics, electromagnetic induction, self and mutual inductance, capacitance, Maxwell's equation in free space and linear isotropic media, boundary conditions of fields at interfaces.

Nonrelativistic quantum mechanics – Planck's law, photoelectric effect, Compton effect, wave-particle duality, Heisenberg's uncertainty principle, quantum mechanics, Schrodinger's equation, and some applications.

Thermodynamics and statistical Physics – laws of thermodynamics and their consequences, thermodynamic potentials and Maxwell's relations, chemical potential, phase equilibrium, phase space, microstates and macrostates, partition function free energy, classical and quantum statistics.

Electronics – semiconductor physics, diode as a circuit element, clipping, clamping, rectification, Zener regulated power supply, transistor as a circuit element, CC CB CE configuration, transistor as a switch, OR and NOT gates feedback in amplifiers.

Operational Amplifier and its applications – inverting, noninverting amplifiers, adder, integrator, differentiator, waveform generator comparator and Schmidt trigger.

Digital integrated circuits – NAND, NOR gates as building blocks, XOR gates, combinational circuits, half and full adder.

Atomic and molecular physics – quantum states of an electron in an atom, Hydrogen atom spectrum, electron spin, spin-orbit coupling, fine structure, Zeeman effect, lasers.

Condensed matter physics – crystal classes, 2D and 3D lattice, reciprocal lattice, bonding, diffraction and structure factor, point defects and dislocations, lattice vibration, free electron theory, electron motion in periodic potential, energy bands in metals, insulators and semiconductors, Hall effect, thermoelectric power, electron transport in semiconductors, dielectrics, Clausius Mossotti equation, Piezo, pyro and ferro electricity.

Nuclear and particle physics – Basics of nuclear properties, nuclear forces, nuclear structures, nuclear reactions, interaction of charged particles and e-m rays with matter, theoretical understanding of radioactive decay, particle physics at the elementary level.

*Computer Science*  
(B.Tech. level)

Data structures - array, stack, queue, linked list, binary tree, heap, AVL tree, B-tree.

Programming languages - Fundamental concepts – abstract data types, procedure call and parameter passing, languages like C and C++.

Design and analysis of algorithms – Asymptotic notation, sorting, selection, searching.

Computer organization and architecture - Number representation, computer arithmetic, memory organization, I/O organization, microprogramming, pipelining, instruction level parallelism.

Operating systems - Memory management, processor management, critical section problem, deadlocks, device management, file systems.

Formal languages and automata theory - Finite automata and regular expressions, pushdown automata, context-free grammars, Turing machines, elements of undecidability.

Principles of Compiler Construction - Lexical analyzer, parser, syntax-directed translation, intermediate code generation.

Database management systems - Relational model, relational algebra, relational calculus, functional dependency, normalization (up to 3rd normal form).

Computer networks - OSI, LAN technology - Bus/tree, Ring, Star; MAC protocols; WAN technology - circuit switching, packet switching; data

communications - data encoding, routing, flow control, error detection/correction, Internetworking, TCP/IP networking including IPv4.  
Switching Theory and Logic Design - Boolean algebra, minimization of Boolean functions, combinational and sequential circuits – synthesis and design.

*Engineering and Technology*  
(B.Tech. level)

Moments of inertia, motion of a particle in two dimensions, elasticity, friction, strength of materials, surface tension, viscosity and gravitation.  
Laws of thermodynamics, and heat engines.  
Electrostatics, magnetostatics and electromagnetic induction.  
Magnetic properties of matter - dia, para and ferromagnetism.  
Laws of electrical circuits - RC, RL and RLC circuits, measurement of current, voltage and resistance.  
D.C. generators, D.C. motors, induction motors, alternators, transformers.  
*p-n* junction, bipolar & FET devices, transistor amplifier, oscillator, multi-vibrator, operational amplifier.  
Digital circuits - logic gates, multiplexer, de-multiplexer, counter, A/D and D/A converters.  
Boolean algebra, minimization of switching functions, combinational and sequential circuits.  
C Programming language.

**Sample Questions**

**GROUP A**

**Mathematics**

A1. If  $1, a_1, a_2, \dots, a_{n-1}$  are the  $n$  roots of unity, find the value of  $(1 - a_1)(1 - a_2)\dots(1 - a_{n-1})$ .

A2. Let

$$S = \{(a_1, a_2, a_3, a_4) : a_i \in \mathfrak{R}, i=1, 2, 3, 4 \text{ and } a_1 + a_2 + a_3 + a_4 = 0\}$$

and

$$\Gamma = \{(a_1, a_2, a_3, a_4) : a_i \in \mathfrak{R}, i=1, 2, 3, 4 \text{ and } a_1 - a_2 + a_3 - a_4 = 0\}.$$

Find a basis for  $S \cap \Gamma$ .

A3. Provide the inverse of the following matrix:

$$\begin{pmatrix} c_0 & c_1 & c_2 & c_3 \\ c_2 & c_3 & c_0 & c_1 \\ c_3 & -c_2 & c_1 & -c_0 \\ c_1 & -c_0 & c_3 & -c_2 \end{pmatrix}$$

where  $c_0 = \frac{1 + \sqrt{3}}{4\sqrt{2}}$ ,  $c_1 = \frac{3 + \sqrt{3}}{4\sqrt{2}}$ ,  $c_2 = \frac{3 - \sqrt{3}}{4\sqrt{2}}$ , and  $c_3 = \frac{1 - \sqrt{3}}{4\sqrt{2}}$ .

(Hint: What is  $c_0^2 + c_1^2 + c_2^2 + c_3^2$ ?)

A4. For any real number  $x$  and for any positive integer  $n$  show that

$$\lceil x \rceil + \left\lceil x + \frac{1}{n} \right\rceil + \left\lceil x + \frac{2}{n} \right\rceil + \dots + \left\lceil x + \frac{n-1}{n} \right\rceil = \lceil nx \rceil$$

where  $\lceil a \rceil$  denotes the largest integer less than or equal to  $a$ .

A5. Let  $b_q b_{q-1} \dots b_1 b_0$  be the binary representation of an integer  $b$ , i.e.,

$$b = \sum_{j=0}^q 2^j b_j, \quad b_j = 0 \text{ or } 1, \text{ for } j = 0, 1, \dots, q.$$

Show that  $b$  is divisible by 3 if  $b_0 - b_1 + b_2 - \dots + (-1)^q b_q = 0$ .

A6. A sequence  $\{x_n\}$  is defined by  $x_1 = \sqrt{2}$ ,  $x_{n+1} = \sqrt{2+x_n}$ ,  $n=1,2, \dots$   
 Show that the sequence converges and find its limit.

A7. Find the following limit:

$$\lim_{n \rightarrow \infty} \left( \frac{1}{\sqrt{n^2+1}} + \frac{1}{\sqrt{n^2+2}} + \dots + \frac{1}{\sqrt{n^2+n}} \right)$$

A8. Find the total number of English words (all of which may not have proper English meaning) of length 10, where all ten letters in a word are not distinct.

A9. Let  $a_0 + \frac{a_1}{2} + \frac{a_2}{3} + \dots + \frac{a_n}{n+1} = 0$ , where  $a_i$ 's are some real constants.

Prove that the equation  $a_0 + a_1x + a_2x^2 + \dots + a_nx^n = 0$  has at least one solution in the interval  $(0, 1)$ .

A10. Let  $\phi(n)$  be the number of positive integers less than  $n$  and having no common factor with  $n$ . For example, for  $n = 8$ , the numbers 1, 3, 5, 7 have no common factors with 8, and hence  $\phi(8) = 4$ . Show that

(i)  $\phi(p) = p - 1$ ,

(ii)  $\phi(pq) = \phi(p)\phi(q)$ , where  $p$  and  $q$  are prime numbers.

A11. Let  $T_n$  be the number of strings of length  $n$  formed by the characters  $a, b$  and  $c$  that do not contain  $cc$  as a substring.

(a) Find the value of  $T_4$ .

(b) Prove that  $T_n \geq 2^{n+1}$  for  $n > 1$ .

A12. Let  $f$  be a real-valued function such that  $f(x+y) = f(x) + f(y) \forall x, y \in \mathbf{R}$ . Define a function  $\phi$  by  $\phi(x) = c + f(x)$ ,  $x \in \mathbf{R}$ , where  $c$  is a real constant. Show that for every positive integer  $n$ ,

$$\phi^n(x) = (c + f(c) + f^2(c) + \dots + f^{n-1}(c)) + f^n(x);$$

where, for a real-valued function  $g$ ,  $g^n(x)$  is defined by

$$g^0(x) = 0, g^1(x) = g(x), g^{k+1}(x) = g(g^k(x)).$$

- A13. Consider a square grazing field with each side of length 8 metres. There is a pillar at the centre of the field (i.e. at the intersection of the two diagonals). A cow is tied to the pillar using a rope of length  $\frac{8}{\sqrt{3}}$  metres. Find the area of the part of the field that the cow is allowed to graze.
- A14. Let  $f: [0,1] \rightarrow [-1,1]$  be such that  $f(0) = 0$  and  $f(x) = \sin \frac{1}{x}$  for  $x > 0$ . Is it possible to get three sequences  $\{a_n\}$ ,  $\{b_n\}$ ,  $\{c_n\}$  satisfying all the three properties P1, P2 and P3 stated below? If so, provide an example sequence for each of the three sequences. Otherwise, prove that it is impossible to get three such sequences.

$$\text{P1: } a_n > 0, b_n > 0, c_n > 0, \text{ for all } n.$$

$$\text{P2: } \lim_{n \rightarrow \infty} a_n = 0, \lim_{n \rightarrow \infty} b_n = 0, \lim_{n \rightarrow \infty} c_n = 0.$$

$$\text{P3: } \lim_{n \rightarrow \infty} f(a_n) = 0, \lim_{n \rightarrow \infty} f(b_n) = 0.5, \lim_{n \rightarrow \infty} f(c_n) = 1.$$

- A15. Let  $a_1 a_2 a_3 \dots a_k$  be the decimal representation of an integer  $a$  ( $a_i \in \{0, \dots, 9\}$  for  $i = 1, 2, \dots, k$ ). For example, if  $a = 1031$ , then  $a_1=1, a_2=0, a_3=3, a_4=1$ . Show that  $a$  is divisible by 11 if and only if

$$\sum_{i \text{ odd}} a_i - \sum_{i \text{ even}} a_i$$

is divisible by 11.

**GROUP B**

**Mathematics**

M1. Let  $0 < x_1 < 1$ . If  $x_{n+1} = \frac{x_n + 3}{3x_n + 1}$ ,  $n = 1, 2, 3, \dots$

(i) Show that  $x_{n+2} = \frac{5x_n + 3}{3x_n + 5}$ ,  $n = 1, 2, 3, \dots$

(ii) Hence or otherwise, show that  $\lim_{n \rightarrow \infty} x_n$  exists.

(iii) Find  $\lim_{n \rightarrow \infty} x_n$ .

M2. (a) A function  $f$  is defined over the real line as follows:

$$f(x) = \begin{cases} x \sin \frac{\pi}{x}, & x > 0 \\ 0, & x = 0. \end{cases}$$

Show that  $f'(x)$  vanishes at infinitely many points in  $(0, 1)$ .

(b) Let  $f : [0, 1] \rightarrow \mathfrak{R}$  be a continuous function with  $f(0) = 0$ . Assume that  $f'$  is finite and increasing on  $(0, 1)$ .

Let  $g(x) = \frac{f(x)}{x}$   $x \in (0, 1)$ . Show that  $g$  is increasing.

M3. Let

$$f(x) = \begin{cases} (x-1)(x^4 + 4x + 7) & \text{if } x \text{ is rational.} \\ (1-x)(x^4 + 4x + 7) & \text{if } x \text{ is irrational.} \end{cases}$$

Find all the continuity points of  $f$ .

M4. Let  $h$  be any fixed positive real number. Show that there is no differentiable function  $f : \mathfrak{R} \rightarrow \mathfrak{R}$  satisfying both the following conditions:

(a)  $f'(0) = 0$ .

(b)  $f'(x) > h$  for all  $x > 0$ .

M5. Find the volume of the solid given by  $0 \leq y \leq 2x$ ,  $x^2 + y^2 \leq 4$  and  $0 \leq z \leq x$ .

M6. (a) Let  $A$ ,  $B$  and  $C$  be  $1 \times n$ ,  $n \times n$  and  $n \times 1$  matrices respectively. Prove or disprove:  $\text{Rank}(ABC) \leq \text{Rank}(AC)$ .

(b) Let  $S$  be the subspace of  $\mathbf{R}^4$  defined by  $S = \{(a_1, a_2, a_3, a_4) : 5a_1 - 2a_3 - 3a_4 = 0\}$ . Find a basis for  $S$ .

M7. (a) A rumour spreads through a population of 5000 people at a rate proportional to the product of the number of people who have heard it and the number who have not. Suppose that 100 people initiate a rumour and that a total of 500 people know the rumour after two days. How long will it take for half the people to hear the rumour? [assume that  $\frac{\log 9}{\log 49} = \frac{129}{229}$ ]

(b) Find the equation of the curve satisfying the differential equation

$$\frac{d^2 y}{dx^2} (x^2 + 1) = 2x \frac{dy}{dx}.$$

M8. (a) Let  $\{a_n : n \geq 1\}$  be a sequence of positive numbers. Define  $b_n = \sqrt{a_{2n-1} a_{2n}}$  for  $n \geq 1$ . If  $a_n$  is monotonic and  $\sum b_n$  converges, prove that  $\sum a_n$  also converges.

(b) Let  $\mathcal{M}$  be the set of all  $3 \times 3$  matrices of the following form:

$$\begin{pmatrix} a & 0 & 0 \\ 0 & a & 0 \\ b & c & a \end{pmatrix}$$

where  $a, b, c \in \mathbb{Z}_2$ . Show that with standard matrix addition and multiplication (over  $\mathbb{Z}_2$ ),  $\mathcal{M}$  is a commutative ring. Find all the idempotent elements of  $\mathcal{M}$ .

M9. Consider the vector space of all  $n \times n$  matrices over  $\mathbb{R}$ .

- (a) Show that there is a basis consisting of only symmetric and skew-symmetric matrices.  
 (b) Find out the number of skew-symmetric matrices this basis must contain.

M10. (a) Let  $G$  be a group. For  $a, b$  in  $G$  we say that  $b$  is *conjugate* to  $a$  (written  $b \sim a$ ), if there exists  $g$  in  $G$  such that  $b = gag^{-1}$ . Show that  $\sim$  is an equivalence relation on  $G$ . The equivalence classes of  $\sim$  are called the *conjugacy classes* of  $G$ . Show that a subgroup  $N$  of  $G$  is normal in  $G$  if and only if  $N$  is a union of conjugacy classes.

(b) Let  $G$  be a group with no proper subgroups. Show that  $G$  is finite. Hence or otherwise, show that  $G$  is cyclic.

M11. Let  $V$  denote the vector space  $\mathfrak{R}^n$ . Suppose  $V_n \rightarrow \mathfrak{R}$  is a function satisfying

- $f(v_1, v_2, \dots, v_n) = 0$  whenever  $v_i = v_j$  for some  $i \neq j$
- $f(v_1, \dots, v_{i-1}, \alpha v_i, v_{i+1}, \dots, v_n) = \alpha f(v_1, \dots, v_{i-1}, v_i, v_{i+1}, \dots, v_n) \forall \alpha \in \mathfrak{R}$
- $f(v_1, \dots, v_{i-1}, v_i + u_i, v_{i+1}, \dots, v_n) = f(v_1, \dots, v_{i-1}, v_i, v_{i+1}, \dots, v_n) + f(v_1, \dots, v_{i-1}, u_i, v_{i+1}, \dots, v_n) \forall u_i \in \mathfrak{R}^n$
- $f(e_1, \dots, e_n) = 1$  where  $e_1 = (1, 0, \dots, 0), e_2 = (0, 1, 0, \dots, 0), \dots, e_n = (0, \dots, 0, 1)$ .

Show that for any  $n \times n$  matrix  $A$ , whose columns are  $v_1, v_2, \dots, v_n$ ,  $f(v_1, v_2, \dots, v_n) = \det(A)$ .

M12. (a) Consider the differential equation:

$$\frac{d^2 y}{dx^2} \cos x + \frac{dy}{dx} \sin x - 2y \cos^3 x = 2 \cos^5 x.$$

By a suitable transformation, reduce this equation to a second order linear differential equation with constant coefficients. Hence or otherwise solve the equation.

(b) Find the surfaces whose tangent planes all pass through the origin.

M13. (a) Draw a simple graph with the degree sequence  $(1, 1, 1, 1, 4)$ .

(b) Write down the adjacency matrix of the graph.

(c) Find the rank of the above matrix.

(d) Using definitions of characteristic root and characteristic vectors only, find out all the characteristic roots of the matrix in (b).

M14. Let  $A$  be any  $n \times n$  real symmetric positive definite matrix. Let  $\lambda$  be the largest eigenvalue of  $A$ .

(a) Show that  $\|Ax\| \leq \lambda x, \quad \forall \|x\| \neq 0$ .

(b) Find  $\text{Sup}_{\|x\| \neq 0} \frac{\|Ax\|}{\|x\|}$ .

M15. Let  $G = (V, E)$  be a connected simple graph. Our objective is to assign a direction to every edge, such that each node has in-degree at least one.

(a) Prove that such an assignment of directions is not possible if  $G$  is a tree.

(b) Prove that such an assignment of directions is always possible if  $G$  is not a tree.

### *Statistics*

S1. (a)  $X$  and  $Y$  are two independent and identically distributed random variables with  $\text{Prob}[X = i] = p_i$ , for  $i = 0, 1, 2, \dots$ . Find  $\text{Prob}[X < Y]$  in terms of the  $p_i$  values.

(b) Based on one random observation  $X$  from  $N(0, \sigma^2)$ , show that  $\sqrt{\pi/2} |X|$  is an unbiased estimate of  $\sigma$ .

S2. (a) Let  $X_0, X_1, X_2, \dots$  be independent and identically distributed random variables with common probability density function  $f$ . A random variable  $N$  is defined as

$$N = n \text{ if } X_1 \leq X_0, X_2 \leq X_0, \dots, X_{n-1} \leq X_0, X_n > X_0, \quad n = 1, 2, 3, \dots$$

Find the probability of  $N = n$ .

(b) Let  $X$  and  $Y$  be independent random variables distributed uniformly over the interval  $[0,1]$ . What is the probability that the integer closest to  $\frac{X}{Y}$  is 2?

S3. Let  $A = \{1,2,3\}$ . You are given a coin with probability of head as  $p$ , where  $0 < p < 1$  and  $p$  is unknown. Suggest a procedure for choosing a number randomly from  $A$  using the given coin, such that  $P(\{1\}) = P(\{2\}) = P(\{3\}) = \frac{1}{3}$ . Justify your answer.

S4. Suppose  $X_1, \dots, X_n$  are independent and have the same Cauchy distribution with location parameter  $\theta$ . The corresponding probability density function is given by

$$f(x : \theta) = \frac{1}{\pi[1 + (x - \theta)^2]}, \quad x, \theta \in \mathfrak{R}.$$

Suppose we want to find the MLE of  $\theta$ .

(a) Show that, for each  $i$

$$E_{\theta} \left[ \frac{\partial \log f(X_i; \theta)}{\partial \theta} \right] = 0, \quad E_{\theta} \left[ -\frac{\partial^2 \log f(X_i; \theta)}{\partial \theta^2} \right] = \frac{1}{2}$$

(b) Write down the likelihood equation.

(c) Write down the successive iterations for  $\theta$  if we want to solve the likelihood equation by the Newton-Raphson method. What is an initial choice for  $\theta$  and why?

S5. Suppose  $X_1, \dots, X_n$  are independent and identically distributed random variables following  $N(\theta, 1)$ ,  $\theta \in \mathbf{R}$ . Let  $\varphi(\theta) = P(X_1 > u_0)$ , where  $u_0$  is a known real number. Show that the uniformly minimum variance unbiased estimate (UMVUE) of  $\varphi(\theta)$  is given by

$$T(X_1, \dots, X_n) = 1 - \Phi \left[ \sqrt{\frac{n}{n-1}} (u_0 - \bar{X}) \right],$$

where  $\Phi(\cdot)$  is the distribution function of the standard normal distribution.

S6. Consider a randomized block design with two blocks and two treatments  $A$  and  $B$ . The following table gives the yields:

	Treatment A	Treatment B
Block 1	$a$	$b$
Block 2	$c$	$d$

- (a) How many orthogonal contrasts are possible with  $a, b, c$  and  $d$ ? Write down all of them.
- (b) Identify the contrasts representing block effects, treatment effects and error.
- (c) Show that their sum of squares equals the total sum of squares.

S7. Let  $X$  be a discrete random variable having the probability mass function

$$p(x) = \Lambda^x(1 - \Lambda)^{1-x}, x = 0, 1,$$

where  $\Lambda$  takes values  $\geq 0.5$  only. Find the most powerful test, based on 2 observations, for testing  $H_0 : \Lambda = \frac{1}{2}$  against  $H_1 : \Lambda = \frac{2}{3}$ , with level of significance 0.05.

S8. Let  $X=(X_1, \dots, X_n)$  be a random sample from the exponential distribution  $E(\theta, \sigma)$  having unknown location parameter  $\theta$  and unknown scale parameter  $\sigma$ . Consider the problem of testing  $H_0: \theta = \theta_0$  against  $H_1: \theta \neq \theta_0$ .

(a) Let  $X_{(1)} \leq X_{(2)} \leq \dots \leq X_{(n)}$  be the order statistics associated with  $\mathbf{X}$ . Let

$$T = \frac{X_{(1)} - \theta_0}{\sum_{i=1}^n (X_i - X_{(1)})}$$

Find the null distribution of  $T$  in terms of an  $F$ -distribution, with degrees of freedom to be obtained by you.

(b) Fix  $0 < \alpha < 1$ , Find  $C_1, C_2$  with  $0 < C_1 < C_2$  such that the test with rejection region " $T \leq C_1$  or  $C_2$ " has size  $\alpha$ .

(c) Show that for any alternative  $(\theta_1, \sigma)$  with  $\theta_1 < \theta_0$ , the power of the level- $\alpha$  test in (b), denoted by  $\beta(\theta_1, \sigma)$ , is given by

$$\beta(\theta_1, \sigma) = 1 - (1 - \alpha) \exp\{-n(\theta_0 - \theta_1) / \sigma\}$$

S9. Let  $X=(X_1, \dots, X_n)$  be a sample from the uniform distribution on  $(0, \theta)$ . Show the following:

(a) For testing  $H_0: \theta \leq \theta_0$  against  $H_1: \theta \geq \theta_0$ , any test is UMP at level  $\alpha$  for which  $E_{\theta_0}(\phi(X)) = \alpha$ ,  $E_{\theta_0}(\phi(X)) \leq \alpha$  for  $\theta \leq \theta_0$ , and  $\phi(x) = 1$  when  $\max(x_1, \dots, x_n) > \theta_0$ .

(b) For testing  $H_0: \theta = \theta_0$  against  $H_1: \theta \neq \theta_0$ , a unique UMP test exists, and is given by  $\phi(x) = 1$  when  $\max(x_1, \dots, x_n) > \theta_0$  or  $\max(x_1, \dots, x_n) \leq \theta_0 \alpha^{1/n}$  and  $\phi(x) = 0$  otherwise.

S10. Consider a simple random sample of  $n$  units, drawn without replacement from a population of  $N$  units. Suppose the value of  $Y_1$  is unusually low whereas that of  $Y_n$  is very high. Consider the following estimator of  $\bar{Y}$ , the population mean.

$$\hat{\bar{Y}} = \begin{cases} \bar{y} + c, & \text{if the sample contains unit 1 but not unit } N; \\ \bar{y} - c, & \text{if the sample contains unit } N \text{ but not unit } 1; \\ \bar{y}, & \text{for all other samples;} \end{cases}$$

where  $\bar{y}$  is sample mean and  $c$  is a constant. Show that  $\hat{\bar{Y}}$  is unbiased. Given that

$$V(\hat{\bar{Y}}) = (1-f) \left[ \frac{S^2}{n} - \frac{2c}{N-1} (Y_N - Y_1 - nc) \right]$$

where  $f = \frac{n}{N}$  and  $S^2 = \frac{1}{N-1} \sum_{i=1}^N (Y_i - \bar{Y})^2$ , comment on the choice of  $c$ .

S11. Suppose  $X_1, \dots, X_n$  are i.i.d. exponential variables with locations parameter  $\theta > 0$  and scale parameter 1. Let  $X_{(1)} = \min\{X_1, \dots, X_n\}$ .

(a) Show that the distribution function of  $T = X_{(1)}$ , denoted by  $F_\theta(t)$ , is a decreasing function of  $\theta$ .

(b) Given  $\alpha$  ( $0 < \alpha < 1$ ), use (a) to obtain a  $(1-\alpha)$  confidence interval for  $\theta$ .

S12. Let  $X_1, X_2, \dots, X_n$  ( $X_i = (x_{i1}, x_{i2}, \dots, x_{ip})$ ,  $i=1, 2, \dots, n$ ) be  $n$  random samples from a  $p$ -variate normal population with mean vector  $\underline{\mu}$  and covariance matrix  $I$ .

Further, let  $S = ((s_{jk}))$  denote the sample sums of squares and products matrix, namely

$$s_{jk} = \sum_{i=1}^n (x_{ij} - \bar{x}_j)(x_{ik} - \bar{x}_k), 1 \leq j, k \leq p, \text{ where}$$

$$\bar{x}_j = \frac{1}{n} \sum_{i=1}^n x_{ij}, 1 \leq j \leq p.$$

Obtain the distribution of  $\ell' S \ell$  where  $\ell \in \mathfrak{R}^k, \ell \neq 0$ .

S13. Suppose  $\mathbf{X} = (X_1, X_2, X_3)^T \sim N_3(\tilde{\mu}, \tilde{\Sigma})$ , where

$$\tilde{\mu} = \begin{pmatrix} \mu_1 \\ \mu_2 \\ \mu_3 \end{pmatrix}, \quad \tilde{\Sigma} = \begin{pmatrix} \sigma_{11} & \sigma_{12} & \sigma_{13} \\ \sigma_{21} & \sigma_{22} & \sigma_{23} \\ \sigma_{31} & \sigma_{32} & \sigma_{33} \end{pmatrix}$$

Show that  $E(X_1, X_2, X_3) = \mu_1 \mu_2 \mu_3 + \mu_1 \sigma_{23} + \mu_2 \sigma_{31} + \mu_3 \sigma_{12}$ .

(b) Suppose  $\mathbf{X} = (X_1, X_2, X_3, X_4)^T \sim N_4(0, \Sigma)$ , where  $\Sigma = ((\sigma_{ij}))$ .

Show that  $E(X_1, X_2, X_3, X_4) = \sigma_{12} \sigma_{34} + \sigma_{13} \sigma_{24} + \sigma_{14} \sigma_{23}$ .

S14. An experimenter wants to study three factors, each at two levels, for their individual effects and interaction effects, if any. If the experimental units are heterogeneous with respect to two factors of classification, suggest a suitable experimental design for the study. Give the analysis of variance (ANOVA) for the suggested design, indicating clearly how the various sums of squares are to be computed.

### *Physics*

P1. (a) In a photoelectric emission experiment, a metal surface was successively exposed to monochromatic lights of wavelength  $\lambda_1$ ,  $\lambda_2$  and  $\lambda_3$ . In each case, the maximum velocity of the emitted photo electrons was measured and found to be  $\alpha$ ,  $\beta$  and  $\gamma$ , respectively.  $\lambda_3$  was 10% higher in value than  $\lambda_1$ , whereas  $\lambda_2$  was 10% lower in value than  $\lambda_1$ . If  $\beta : \gamma = 4 : 3$ , then show that

$$\alpha : \beta = 9\sqrt{3} : 8\sqrt{5}.$$

(b) The nucleus  $B_Z^A$  decays by *alpha* ( $He_2^4$ ) emission with a *half-life*  $T$  to the nucleus  $C_{Z-2}^{A-4}$  which in turn, decays by *beta* (electron) emission with a *half-life*  $\frac{T}{4}$  to the nucleus  $D_{Z-1}^{A-4}$ . If at time  $t = 0$ , the decay chain  $B \rightarrow C \rightarrow D$  had started with  $B_0$  number of  $B$  nuclei only, then find out the time  $t$  at which the number of  $C$  nuclei will be maximum.

P2. (a) Consider a material that has two solid phases, a metallic phase and an insulator phase. The phase transition takes place at the temperature  $T_0$  which is well below the Debye temperature for either phase. The high temperature phase is metastable all the way down to  $T = 0$  and the speed of sound,  $c_s$ , is the same for each phase. The contribution to the heat capacity coming from the free electrons to the metal is

$$C_e = \rho_e V \gamma T, \quad \gamma = 3\pi^2 \frac{k}{4T_F}$$

where  $\rho_e$  is the number density of the free electrons,  $T_F$  is the Fermi temperature,  $K$  is the Boltzmann constant, and  $V$  is the volume. Calculate the latent heat per unit volume required to go from the low temperature phase to the high temperature phase at  $T = T_0$ . Which phase is the high temperature phase?

(b) Consider two hypothetical shells centred on the nucleus of a hydrogen atom with radii  $r$  and  $r + dr$ .

(i) Find out the probability that the electrons will be between the shells. Assume the wave function for the ground state of the hydrogen atom as

$$\psi = \frac{1}{\sqrt{\pi a_0^3}} e^{-\frac{r}{a_0}} \cos(\pi r)$$

(ii) If the wave function for the ground state of the hydrogen atom is given by

$$\psi = \frac{1}{\sqrt{\pi a_0^3}} e^{-\frac{r}{a_0}}$$

what will be the most probable distance of the electron from the nucleus?

- P3. (a) A particle of mass  $m$  moves under a force directed towards a fixed point and this force depends on the distance from the fixed point. Show that

- (i) the particle will be constrained to move in a plane, and
- (ii) the areal velocity of the particle is constant.

(b) If the force  $\mathbf{F}$  varies as the inverse of the square of the distance, show that

$$\nabla \times \mathbf{F} = 0.$$

Discuss its implications.

(c) Assuming the trajectory of planets to be circular, deduce the force law from Kepler's third law.

- P4. (a) A mass  $m$  is attached to a massless spring of spring constant  $K$  via a frictionless pulley of radius  $R$  and mass  $M$  as shown in following figure. The mass  $m$  is pulled down through a small distance  $x$  and released, so that it is set into simple harmonic motion. Find the frequency of the vertical oscillation of the mass  $m$ .

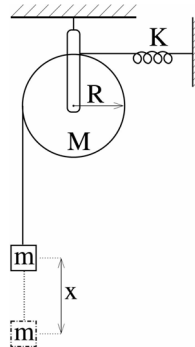

- (b) The Hamiltonian of a mechanical system having two degrees of freedom is:

$$H(x, y; p_x, p_y) = \frac{1}{2m} (p_x^2 + p_y^2) + \frac{1}{2} m \omega^2 (x^2 + y^2),$$

where  $m$  and  $\omega$  are constants;  $x, y$  are the generalized co-ordinates for which  $p_x, p_y$  are the respective conjugate momenta. Show that the expressions  $(x p_y - y p_x)^n$ ,  $n=1,2,3,\dots$  are constants of motion for this system.

- P5. (a) A particle describes the curve  $r^n = a \cos n\theta$  under a force  $P$  towards the pole,  $r, \theta$  being the polar coordinates. Find the law of force.
- (b) Two particles, each with speed  $v$ , move in a plane making an angle  $2\theta$  with each other as seen from the laboratory frame. Calculate the relative speed (under the formalism of special relativity) of one with respect to the other.
- P6. (a) A dielectric sphere of radius  $R$  and permittivity  $\epsilon$  carries a volume charge density  $\rho(r) = kr$  (where  $k$  is a constant). Deduce an expression for the energy of the configuration.
- (b) Two spherical cavities of radii  $a$  and  $b$  are hollowed out from the interior of a neutral conducting sphere of radius  $R$ . Two point charges of magnitude  $q_a$  and  $q_b$  are now placed at the centres of the two cavities as shown in the figure.
- (ii) Calculate the surface charge densities on the surfaces of the two spherical cavities and the sphere.
- (iii) What are the magnitudes of the forces on  $q_a$  and  $q_b$ ?

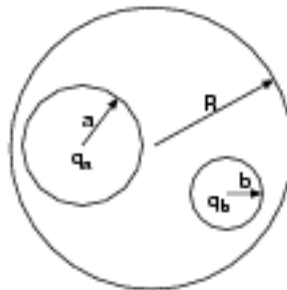

- P7. A person standing at the rear end of a train fires a bullet towards the front of the train. The speed of the bullet and the length of the train, as measured in the frame of the train, are  $0.5c$  and  $400\text{m}$  respectively. The train is moving at  $0.6c$  as measured by an observer on the ground. What does the ground observer measure for

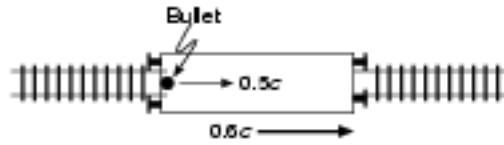

- (i) the length of the train,
- (ii) the speed of the bullet, and
- (iii) the time required for the bullet to reach the front of the train?

P8. A particle of mass  $m$  moves along a trajectory given by

$$x = a (\theta - \sin\theta)$$

$$y = a (1 + \cos\theta)$$

where  $0 \leq \theta \leq 2\pi$  and the  $x$ -axis and  $y$ -axis are in the horizontal and vertical directions respectively, with respect to the Earth's surface.

- (a) Write the Lagrangian function of the particle.
- (b) Derive the equation of motion from the Lagrangian.

P9. In the circuit shown below, the peak current flowing through the different branches are indicated. Derive the value of the total power delivered by the source.

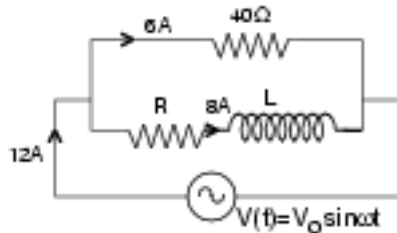

P10. Two heavy bodies  $A$  and  $B$ , each having charge  $-Q$ , are kept rigidly fixed at a distance  $2a$  apart. A small particle  $C$  of mass  $m$  and charge  $+q$  ( $\ll Q$ ), is placed at the midpoint of the straight line joining the centers of  $A$  and  $B$ .  $C$  is now displaced slightly along a direction perpendicular to the line joining  $A$  and  $B$ , and then released. Find the period of the resultant oscillatory motion of  $C$ , assuming its displacement  $y \ll a$ .

If instead,  $C$  is slightly displaced towards  $A$ , then find the instantaneous velocity of  $C$ , when the distance between  $A$  and  $C$  is  $\frac{a}{2}$ .

- P11. An elementary particle called  $\Sigma^-$ , at rest in laboratory frame, decays spontaneously into two other particles according to  $\Sigma^- \rightarrow \pi^- + n$ . The masses of  $\Sigma^-$ ,  $\pi^-$  and  $n$  are  $M_1$ ,  $m_1$ , and  $m_2$  respectively.
- (a) How much kinetic energy is generated in the decay process?
- (b) What are the ratios of kinetic energies and momenta of  $\pi^-$  and  $n$ ?
- P12. Consider the following truth table where  $A$ ,  $B$  and  $C$  are Boolean inputs and  $T$  is the Boolean output.

A	B	C	T
0	0	0	1
0	0	1	0
0	1	0	0
0	1	1	1
1	0	0	0
1	0	1	1
1	1	0	0
1	1	1	1

Express  $T$  in a product-of-sum form and hence, show how  $T$  can be implemented using NOR gates only.

- P13. (a) Find the relationship between  $L$ ,  $C$  and  $R$  in the circuit shown in the figure such that the impedance of the circuit is independent of frequency. Find out the impedance.

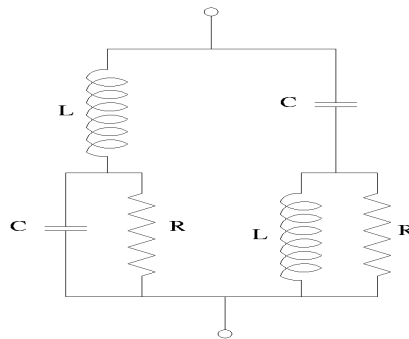

- (b) Find the value of  $R$  and the current flowing through  $R$  shown in the figure when the current is zero through  $R'$ .

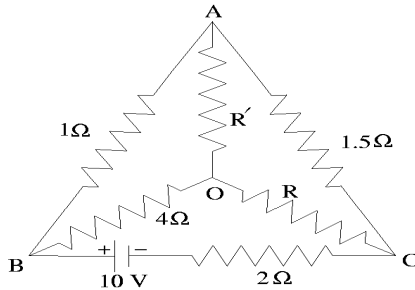

- P14. A gas obeys the equation of state  $P = \frac{\tau}{V} + \frac{B(\tau)}{V^2}$  where  $B(\tau)$  is a function of temperature  $\tau$  only. The gas is initially at temperature  $\tau$  and volume  $V_0$  and is expanded isothermally and reversibly to volume  $V_1 = 2V_0$ .
- (a) Find the work done in the expansion.  
 (b) Find the heat absorbed in the expansion.

(Hint: Use the relation  $\left(\frac{\partial S}{\partial V}\right)_\tau = \left(\frac{\partial P}{\partial \tau}\right)_V$  where the symbols have their usual meaning.)

- P15. Consider the following circuit where the triangular symbol represents an ideal op-amp.

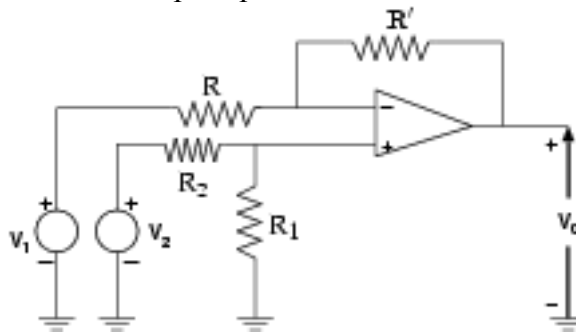

- (a) Calculate the output voltage  $v_0$  for the (i) common-mode operation and (ii) difference mode operation.

(b) Also calculate the value of the common-mode rejection ratio for  $R_1/R_2 = R_1/R_2$ .

P16. (a) A particle of mass  $m$  is moving in a plane under the action of an attractive force proportional to  $1/r^2$ ,  $r$  being the radial distance of the particle from the fixed point. Write the Lagrangian of the system and using the Lagrangian show that the areal velocity of the particle is conserved (Kepler's second law).

(b) A particle of mass  $m$  and charge  $q$  is moving in an electromagnetic field with velocity  $v$ . Write the Lagrangian of the system and hence find the expression for the generalized momentum.

### Computer Science

C1. (a) A grammar is said to be left recursive if it has a non-terminal  $A$  such that there is a derivation  $A \Rightarrow^+ A\alpha$  for some sequence of symbols  $\alpha$ . Is the following grammar left-recursive? If so, write an equivalent grammar that is not left-recursive.

$$\begin{array}{ll} A \rightarrow Bb & A \rightarrow a \\ B \rightarrow Cc & B \rightarrow b \\ C \rightarrow Aa & C \rightarrow c \end{array}$$

(b) An example of a function definition in C language is given below:

```
char fun (int a, float b, int c)
{ /* body */ ... }
```

Assuming that the only types allowed are char, int, float (no arrays, no pointers, etc.), write a grammar for function headers, i.e., the portion `char fun(int a, ...)` in the above example.

(c) Consider the floating point number representation in the C programming language.

Give a regular expression for it using the following convention:

$l$  denotes a letter,  $d$  denotes a digit,  $S$  denotes sign and  $P$  denotes point.

State any assumption that you may need to make.

C2. The following functional dependencies are defined on the relation  $\mathcal{R}(A, B, C, D, E, F)$ :

$$\{ A \rightarrow B, AB \rightarrow C, BC \rightarrow D, CD \rightarrow E, E \rightarrow A \}$$

- (a) Find the candidate keys for  $\mathcal{R}$ .
- (b) Is  $\mathcal{R}$  normalized? If not, create a set of normalized relations by decomposing  $\mathcal{R}$  using only the given set of functional dependencies.
- (c) If a new attribute  $F$  is added to  $\mathcal{R}$  to create a new relation  $\mathcal{R}'(A, B, C, D, E, F)$  without any addition to the set of functional dependencies, what would be the new set of candidate keys for  $\mathcal{R}'$ ?
- (d) What is the new set of normalized relations that can be derived by decomposing  $\mathcal{R}'$  for the same set of functional dependencies?
- (e) If a new dependency is declared as follows:  
*For each value of  $A$ , attribute  $F$  can have two values,*  
what would be the new set of normalized relations that can be created by decomposing  $\mathcal{R}'$ ?

C3.(a) A relation  $R(\underline{A}, B, C, D)$  has to be accessed under the query  $\sigma_{B=10}(R)$ . Out of the following possible file structures, which one should be chosen and why?

- i)  $R$  is a heap file.
  - ii)  $R$  has a clustered hash index on  $B$ .
  - iii)  $R$  has an unclustered  $B^+$  tree index on  $(A, B)$ .
- (b) If the query is modified as  $\pi_{A,B}(\sigma_{B=10}(R))$ , which one of the three possible file structures given above should be chosen in this case and why?
- (c) Let the relation have 5000 tuples with 10 tuples/page. In case of a hashed file, each bucket needs 10 pages. In case of  $B^+$  tree, the index structure itself needs 2 pages. If it takes 25 msec. to read or write a disk page, what would be the disk access time for answering the above queries?
- (d) Relation  $R(A, B, C)$  supports the following functional dependencies:

$$A \rightarrow B, B \rightarrow C \text{ and } C \rightarrow A.$$

- (i) Identify the key attributes.
  - (ii) Explain whether R is in BCNF.
  - (iii) If R is not in BCNF, decompose to create a set of normalized relations satisfying BCNF.
  - (iv) If R does not support the functional dependencies  $B \rightarrow C$ , but the other two are maintained, would R be in BCNF? If not, decompose R to normalized relations satisfying BCNF.
- C4. Let  $A$  and  $B$  be two arrays, each of size  $n$ .  $A$  and  $B$  contain numbers in sorted order. Give an  $O(\log n)$  algorithm to find the median of the combined set of  $2n$  numbers.
- C5. (a) Consider a pipelined processor with  $m$  stages. The processing time at every stage is the same. What is the speed-up achieved by the pipelining?
- (b) In a certain computer system with cache memory, 750 ns (nanosec) is the access time for main memory for a cache miss and 50 ns is the access time for a cache hit. Find the percentage decrease in the effective access time if the hit ratio is increased from 80% to 90%.
- C6. (a) A disk has 500 bytes/sector, 100 sectors/track, 20 heads and 1000 cylinders. The speed of rotation of the disk is 6000 rpm. The average seek time is 10 millisecs. A file of size 50 MB is written from the beginning of a cylinder and a new cylinder will be allocated only after the first cylinder is totally occupied.
- i) Find the maximum transfer rate.
  - ii) How much time will be required to transfer the file of 50 MB written on the disk? Ignore the rotational delay but not the seek time.
- (b) Consider a 4-way traffic crossing as shown in the figure.

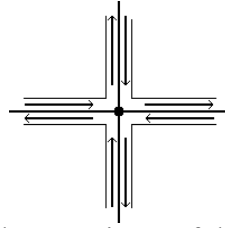

Suppose that we model the crossing as follows:

- each vehicle is modeled by a process,
- the crossing is modeled as a shared data structure. Assume that the vehicles can only move straight through the intersection (no left or right turns). Using read-write locks (or any standard synchronization primitive), you have to devise a synchronization scheme for the processes. Your scheme should satisfy the following criteria:
  - i) prevent collisions,
  - ii) prevent deadlock, and
  - iii) maximize concurrency but prevent indefinite waiting (starvation).

Write down the algorithm that each vehicle must follow in order to pass through the crossing. Justify that your algorithm satisfies the given criteria.

- C7.
- (a) A computer on a 6 Mbps network is regulated by a token bucket. The bucket is filled at a rate of 2 Mbps. It is initially filled to capacity with 8 Megabits. How long can the computer transmit at the full 6 Mbps?
  - (b) Sketch the Manchester encoding for the bit stream 0001110101.
  - (c) If delays are recorded in 8-bit numbers in a 50-router network, and delay vectors are exchanged twice a second, how much bandwidth per (full-duplex) line is consumed by the distributed routing algorithm? Assume that each router has 3 lines to other routers.
  - (d) Consider three IP networks  $X$ ,  $Y$ , and  $Z$ . Host  $H_X$  in the network  $X$  sends messages, each containing 180 bytes of application data, to a host  $H_Z$  in network  $Z$ . The TCP layer prefixes a 20 byte header to the message. This passes through an intermediate network  $Y$ . The maximum packet size, including 20 byte IP header, in each network is  $X$ : 1000 bytes,  $Y$ : 100 bytes, and  $Z$ : 1000 bytes. The networks  $X$  and  $Y$  are

connected through a 1 Mbps link, while  $Y$  and  $Z$  are connected by a 512 Kbps link.

(i) Assuming that the packets are correctly delivered, how many bytes, including headers, are delivered to the IP layer at the destination for one application message? Consider only data packets.

(ii) What is the rate at which application data is transferred to host  $H_Z$ ? Ignore errors, acknowledgements, and other overheads.

C8. Consider a binary operation *shuffle* on two strings, that is just like shuffling a deck of cards. For example, the operation *shuffle* on strings  $ab$  and  $cd$ , denoted by  $ab \parallel cd$ , gives the set of strings  $\{abcd, acbd, acdb, cabd, cadb, cdab\}$ .

(a) Define formally by induction the *shuffle* operation on any two strings  $x, y \in \Sigma^*$ .

(b) Let the *shuffle* of two languages  $A$  and  $B$ , denoted by  $A \parallel B$  be the set of all strings obtained by shuffling a string  $x \in A$  with a string  $y \in B$ . Show that if  $A$  and  $B$  are regular, then so is  $A \parallel B$ .

C9. (a) Give a method of encoding the microinstructions (given in the table below) so that the minimum number of control bits are used and maximum parallelism among the microinstructions is achieved.

Microinstructions	Control signals
$I_1$	$C_1, C_2, C_3, C_4, C_5, C_6,$
$I_2$	$C_1, C_3, C_4, C_6,$
$I_3$	$C_2, C_5, C_6,$
$I_4$	$C_4, C_5, C_8,$
$I_5$	$C_7, C_8,$
$I_6$	$C_1, C_8, C_9,$
$I_7$	$C_3, C_4, C_8,$
$I_8$	$C_1, C_2, C_9,$

(b) A certain four-input gate  $G$  realizes the switching function

$$G(a, b, c, d) = abc + bcd.$$

Assuming that the input variables are available in both complemented and uncomplemented forms:

(i) Show a realization of the function

$$f(u, v, w, x) = \Sigma(0, 1, 6, 9, 10, 11, 14, 15)$$

with only three  $G$  gates and one  $OR$  gate.

(ii) Can all switching functions be realized with  $\{G, OR\}$  logic set?

C10. Consider a set of  $n$  temperature readings stored in an array  $T$ . Assume that a temperature is represented by an integer. Design an  $O(n + k \log n)$  algorithm for finding the  $k$  coldest temperatures.

C11. Assume the following characteristics of instruction execution in a given computer:

- ALU/register transfer operations need 1 clock cycle each,
- each of the load/store instructions needs 3 clock cycles, and
- branch instructions need 2 clock cycles each.

(a) Consider a program which consists of 40% ALU/register transfer instructions, 30% load/store instructions, and 30% branch instructions. If the total number of instructions in this program is 10 billion and the clock frequency is 1 GHz, then compute the average number of cycles per instruction (CPI), total execution time for this program, and the corresponding MIPS rate.

(b) If we now use an optimizing compiler which reduces the total number of ALU/register transfer instructions by a factor of 2, keeping the number of other instruction types unchanged, then compute the average CPI, total time of execution and the corresponding MIPS rate for this modified program.

C12. Consider a computer system with 1 GB main memory and 1 MB cache memory organized in blocks of 64 bytes.

(a) What is the minimum number of bits needed for addressing a memory location?

(b) How many bits are needed for the tag field and the index field if the cache memory is organized in the following ways: (i) direct-mapped, (ii) fully associative, and (iii) 2-way set-associative?

(c) Suppose the memory location to be accessed is 000D0237 (in hex). What cache block will be accessed for this memory location in the direct-mapped organization and what will be the value of the tag field? If instead, the cache memory were organized in a fully associative manner, what will be the corresponding value of the tag field?

(d) Express the following numbers in IEEE 754-1985 single precision floating-point format:

- (i) -0 (ii)  $2.5 \times 2^{-130}$  (iii) 230 (iv) 0.875 (v)  $(-3)^{1/8}$ .

C13. A tape  $S$  contains  $n$  records, each representing a vote in an election. Each candidate for the election has a unique  $id$ . A vote for a candidate is recorded as his/her  $id$ .

- (i) Write an  $O(n)$  time algorithm to find the candidate who wins the election. Comment on the main memory space required by your algorithm.  
 (ii) If the number of candidates  $k$  is known *a priori*, can you improve your algorithm to reduce the time and/or space complexity?  
 (iii) If the number of candidates  $k$  is unknown, modify your algorithm so that it uses only  $O(k)$  space. What is the time complexity of your modified algorithm?

C14. (a) The *order* of a regular language  $L$  is the smallest integer  $k$  for which  $L^k = L^{k+1}$ , if there exists such a  $k$ , and  $\infty$  otherwise.

- (i) What is the order of the regular language  $a + (aa)(aaa)^*$ ?  
 (ii) Show that the order of  $L$  is finite if and only if there is an integer  $k$  such that  $L^k = L^*$ , and that in this case the order of  $L$  is the smallest  $k$  such that  $L^k = L^*$ .

(b) Solve for  $T(n)$  given by the following recurrence relations:

$$T(1) = 1;$$

$$T(n) = 2T(n/2) + n \log n, \text{ where } n \text{ is a power of } 2.$$

(c) An A.P. is  $\{p + qn \mid n = 0, 1, \dots\}$  for some  $p, q \in \mathbb{N}$ . Show that if  $L \subseteq \{a\}^*$  and  $\{n \mid a^n \in L\}$  is an A.P., then  $L$  is regular.

C15. (a) You are given an unordered sequence of  $n$  integers with many duplications, such that the number of distinct integers in the sequence is  $O(\log n)$ . Design a sorting algorithm and its necessary data structure(s), which can sort the sequence using

at most  $O(n \log(\log n))$  time. (You have to justify the time complexity of your proposed algorithm.)

- (b) Let  $A$  be a real-valued matrix of order  $n \times n$  already stored in memory. Its  $(i, j)$ -th element is denoted by  $a[i, j]$ . The elements of the matrix  $A$  satisfy the following property:  
 Let the largest element in row  $i$  occur in column  $l_i$ . Now, for any two rows  $i_1, i_2$ , if  $i_1 < i_2$ , then  $l_{i_1} \leq l_{i_2}$ .

2	6	4	5	3
5	3	7	2	4
4	2	10	7	8
6	4	5	9	7
3	7	6	8	12

(a)

Row $I$	$l(i)$
1	2
2	3
3	3
4	4
5	5

(b)

Figure shows an example of (a) matrix  $A$ , and (b) the corresponding values of  $l_i$  for each row  $i$ .

Write an algorithm for identifying the largest valued element in matrix  $A$  which performs at most  $O(n \log_2 n)$  comparisons.

C16. You are given the following file abc.h:

```
#include <stdio.h>
#define SQR(x) (x*x)
#define ADD1(x) (x=x+1)
#define BeginProgram int main(int ac,char *av[]){
#define EndProgram return 1; }
```

For each of the following code fragments, what will be the output?

- (i) #include "abc.h"  
main()  
{ int y = 4; printf("%d\n", SQR(y+1)); }
- (ii) #include "abc.h"  
BeginProgram  
int y=3; printf("%d\n", SQR(ADD1(y)));  
EndProgram

### ***Engineering and Technology***

E1. A bullet of mass  $M$  is fired with a velocity of  $40$  m/s at an angle  $\theta$  with the horizontal plane. At  $P$ , the highest point of its trajectory, the bullet collides with a bob of mass  $3M$  suspended freely by a mass-less string of length  $\frac{3}{10}$  m. After the collision, the bullet gets stuck inside the bob and the string deflects with the total mass through an angle of  $120^\circ$  keeping the string taut. Find

- (i) the angle  $\theta$ , and  
(ii) the height of  $P$  from the horizontal plane.  
Assume,  $g = 10 \text{ m/s}^2$ , and friction in air is negligible.

E2. (a) A rigid horizontal bar of negligible weight is supported by two springs as shown in the figure below. Determine the distance  $x$  in order that the bar remains horizontal after a load  $P$  is applied.

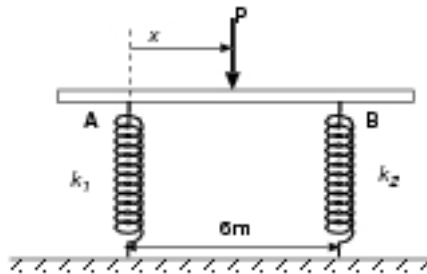

(b) A composite shaft of Aluminium and Brass is rigidly supported at the ends  $A$  and  $C$ , as shown in the figure below. The shaft is subjected to a shearing stress by the application of a torque  $T$ . Calculate the ratio of lengths  $AB : BC$  if each part of the shaft is stressed to its maximum limit (beyond which the composite shaft will break). Assume the maximum shear stress of Brass and Aluminium to be  $560 \text{ kg/cm}^2$  and  $420 \text{ kg/cm}^2$  respectively. Also assume that the modulus of rigidity of Brass is twice that of Aluminium.

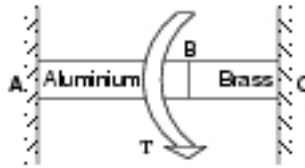

- E3. Find the acceleration of the block of mass  $M$  in the situation shown below. The coefficient of friction between the blocks is  $\mu_1$  and that between the bigger block and the ground is  $\mu_2$ .

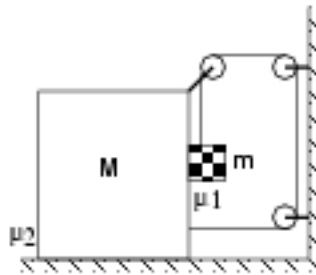

- E4. A flywheel of mass  $100 \text{ kg}$  and radius of gyration  $20 \text{ cm}$  is mounted on a light horizontal axle of radius  $2 \text{ cm}$ , and is free to rotate on bearings whose friction may be neglected. A light string wound on the axle carries at its free end a mass of  $5 \text{ kg}$ . The system is released from rest with the  $5 \text{ kg}$  mass hanging freely. If the string slips off the axle after the weight has descended  $2 \text{ m}$ , prove that a couple of moment  $10/\pi^2 \text{ kg.wt.cm.}$  must be applied in order to bring the flywheel to rest in  $5$  revolutions.
- E5. The truss shown in the figure rotates around the pivot  $O$  in a vertical plane at a constant angular speed  $\omega$ . Four equal masses ( $m$ ) hang from

the points B, C, D and E. The members of the truss are rigid, weightless and of equal length. Find a condition on the angular speed  $\omega$  so that there is compression in the member OE.

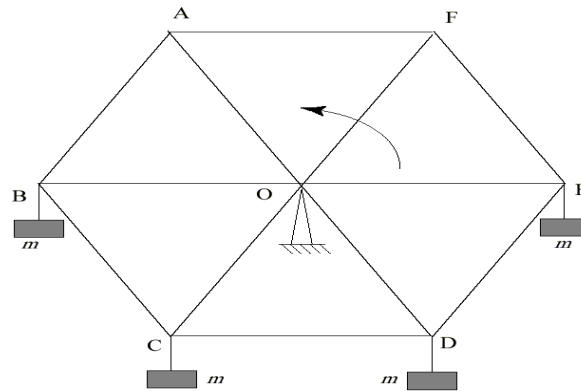

- E6. If the inputs A and B to the circuit shown below can be either 0 volt or 5 volts,
- what would be the corresponding voltages at output Z, and
  - what operation is being performed by this circuit ?
- Assume that the transistor and the diodes are ideal and base to emitter saturation voltage = 0.5 volts.

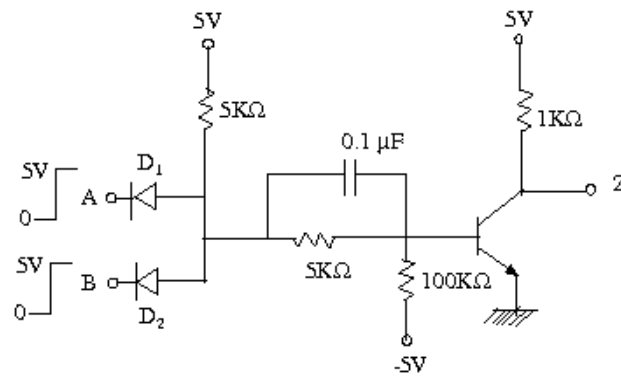

- E7. Two bulbs of 500 cc capacity are connected by a tube of length 20 cm and internal radius 0.15 cm. The whole system is filled with oxygen, the initial pressures in the bulbs before connection being 10 cm and 15 cm of Hg, respectively. Calculate the time taken for the pressures

to become 12 cm and 13 cm of Hg, respectively. Assume that the coefficient of viscosity  $\eta$  of oxygen is 0.000199 cgs unit.

E8. (a) Ice in a cold storage melts at a rate of  $\frac{300 \times 3.6}{80 \times 4.2}$  kg/hour when the external temperature is  $27^\circ\text{C}$ . Find the minimum power output of the refrigerator motor, which just prevents the ice from melting. (Latent heat of fusion of ice = 80 cal/gm.)

(b) A vertical hollow cylinder contains an ideal gas with a 5 kg piston placed over it. The cross-section of the cylinder is  $5 \times 10^{-3} \text{ m}^2$ . The gas is heated from 300 K to 350 K and the piston rises by 0.1 m. The piston is now clamped in this position and the gas is cooled back to 300 K. Find the difference between the heat energy added during heating and that released during cooling. (1 atmospheric pressure =  $10^5 \text{ Nm}^{-2}$  and  $g = 10 \text{ ms}^{-2}$ .)

E9. (a) A system receives 10 Kcal of heat from a reservoir to do 15 Kcal of work. How much work must the system do to reach the initial state by an adiabatic process?

(b) A certain volume of Helium at  $15^\circ\text{C}$  is suddenly expanded to 8 times its volume. Calculate the change in temperature (assume that the ratio of specific heats is 5/3).

E10. A spherical charge distribution has a volume density  $\rho$ , which is a function of  $r$ , the radial distance from the center of the sphere, as given below.

$$\rho = \begin{cases} A/r, & A \text{ is constant for } 0 \leq r \leq R \\ 0, & \text{for } r > R \end{cases}$$

Determine the electric field as a function of  $r$ , for  $r \geq R$ . Also deduce the expression for the electrostatic potential energy  $U(r)$ , given that  $U(\infty) = 0$  in the region  $r \geq R$ .

E11. Consider the distribution of charges as shown in the figure below. Determine the potential and field at the point  $p$ .

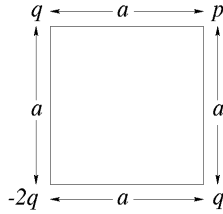

- E12. A proton of velocity  $10^7$  m/s is projected at right angles to a uniform magnetic induction field of  $0.1$  w/m<sup>2</sup>. How much is the path of the particle deflected from a straight line after it has traversed a distance of  $1$  cm? How long does it take for the proton to traverse a  $90^\circ$  arc?
- E13. (a) State the two necessary conditions under which a feedback amplifier circuit becomes an oscillator.  
 (b) A two-stage FET phase shift oscillator is shown in the diagram below.

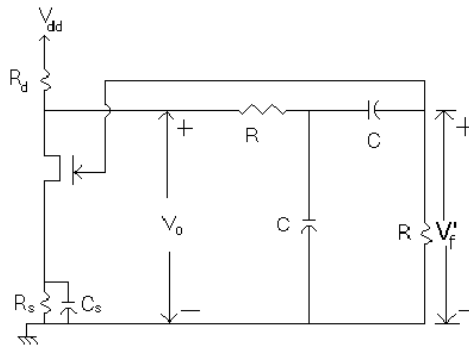

- (i) Derive an expression for the feedback factor  $\beta$ .  
 (ii) Find the frequency of oscillation.  
 (iii) Establish that the gain  $A$  must exceed  $3$ .
- E14. A circular disc of radius  $10$ cm is rotated about its own axis in a uniform magnetic field of  $100$  weber/m<sup>2</sup>, the magnetic field being perpendicular to the plane of the disc. Will there be any voltage developed across the disc? If so, then find the magnitude of this voltage when the speed of rotation of the disc is  $1200$  rpm.
- E15. A 3-phase,  $50$ -Hz,  $500$ -volt,  $6$ -pole induction motor gives an output of  $50$  HP at  $900$  rpm. The frictional and windage losses total  $4$  HP and the stator losses amount to  $5$  HP. Determine the slip, rotor copper loss, and efficiency for this load.

- E16. A d.c. shunt motor running at a speed of 500rpm draws 44KW power with a line voltage of 220V from a d.c. shunt generator. The field resistance and the armature resistance of both the machines are  $55 \Omega$  and  $0.025 \Omega$  respectively. However, the voltage drop per brush is 1.05V in the motor, and that in the generator is 0.95V. Calculate
- the speed of the generator in rpm, and
  - the efficiency of the overall system ignoring losses other than the copper-loss and the loss at the brushes.
- E17. An alternator on open-circuit generates 360 V at 60 Hz when the field current is 3.6 A. Neglecting saturation, determine the open-circuit e.m.f. when the frequency is 40 Hz and the field-current is 24A.
- E18. A single phase two-winding 20 KVA transformer has 5000 primary and 500 secondary turns. It is converted to an autotransformer employing additive polarity mechanism. Suppose the transformer always operates with an input voltage of 2000 V.
- Calculate the percentage increase in KVA capacity.
  - Calculate the common current in the autotransformer.
  - At full load of 0.9 power factor, if the efficiency of the two-winding transformer be 90%, what will be the efficiency of the autotransformer at the same load?
- E19. The hybrid parameters of a *p-n-p* junction transistor used as an amplifier in the common-emitter configuration are:  $h_{ie} = 800\Omega$ ,  $h_{fe} = 46$ ,  $h_{oe} = 8 \times 10^{-5}$  mho,  $h_{re} = 55.4 \times 10^{-4}$ . If the load resistance is 5 k $\Omega$  and the effective source resistance is 500  $\Omega$ , calculate the voltage and current gains and the output resistance.
- E20. (a) Derive the equivalent lattice network corresponding to the bridged *T* network shown in the figure.

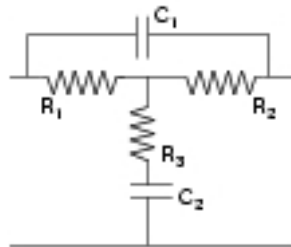

(b) Find the open-circuit transfer impedance of the lattice shown in the figure below and determine the condition for having no zeros in the right-half plane, i.e., for positive frequencies.

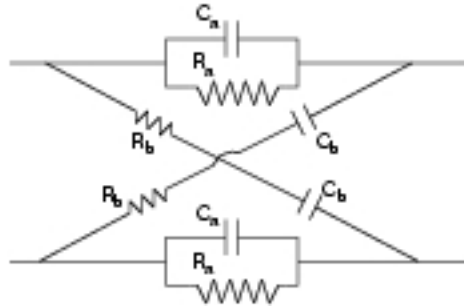

E21. A logic circuit operating on Binary Coded Decimal (BCD) digits has four inputs  $X_1, X_2, X_3,$  and  $X_4$ , where  $X_1X_2X_3X_4$  represents a BCD digit. The circuit has two output lines  $Z_1$  and  $Z_2$ . Output  $Z_1$  is 1 only when the decimal digit corresponding to the inputs  $X_1, X_2, X_3, X_4$  is 0 or a power of 2. Output  $Z_2$  is 1 only when the decimal digit corresponding to the inputs is 1 or a power of 3. Find a minimum cost realization of the above circuit using NAND gates.

E22. (a) Using the minimum number of flip-flops, design a special purpose counter to provide the following sequence:

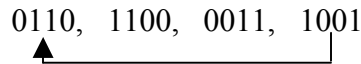

(b) Find the currents  $I_1$  and  $I_2$  in the following circuit.

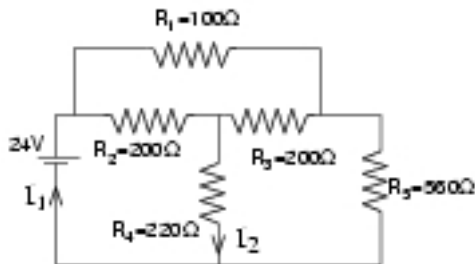

E23. Write a C program to generate a sequence of positive integers between 1 and N, such that each of them has only 2 or/and 3 as prime factors. For example, the first seven elements of the sequence are: 2, 3, 4, 6, 8, 9, 12. Justify the steps of your algorithm.

E24. Design a circuit using the module, as shown in the figure below, to compute a solution of the following set of equations:

$$3x + 6y - 10 = 0$$

$$2x - y - 8 = 0$$

A module consists of an ideal OP-AMP and 3 resistors, and you may use multiple copies of such a module. Voltage inverters and sources may be used, if required.